

BACCALAURÉAT PROFESSIONNEL
OUVRAGES DU BÂTIMENT
Aluminium, verre et matériaux de synthèse

Session 2010

Durée : 3 heures

Coefficient : 2

**EPREUVE E2 (U2) - Préparation et suivi d'une
fabrication et d'une mise en œuvre sur chantier**

Ce dossier comporte 9 pages, numérotées de DTC 1 / 9 à DTC 9 / 9.
Assurez-vous que cet exemplaire est complet.
S'il est incomplet, demandez un autre exemplaire au chef de salle.

DOCUMENT GAMMISTE PORTE BATTANTE SANS SEUIL OUVERTURE VERS L'INTERIEUR 1 ET 2 VANTAUX

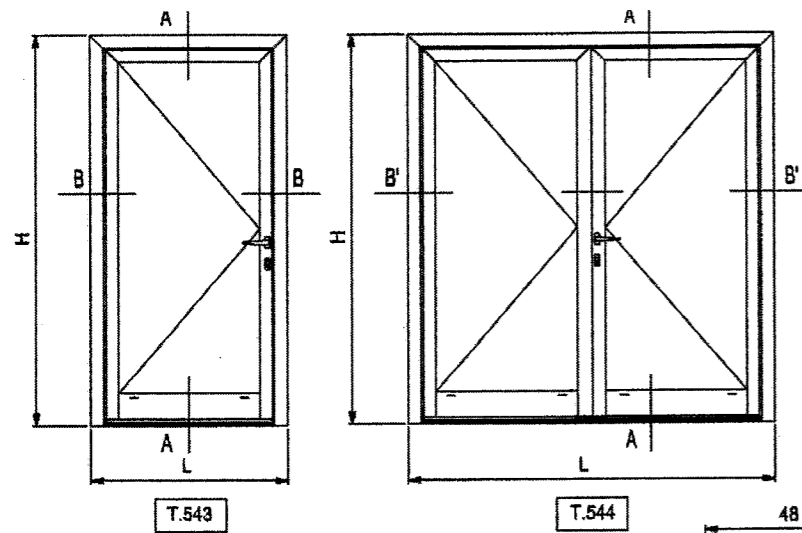

COUPE B Ech. 1/2
SECTION B Scale 1/2

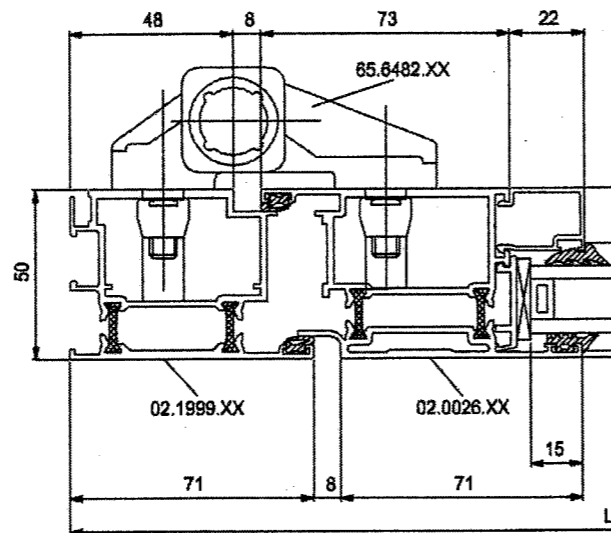

Des noeuds Echelle 1 sont présentés aux
planches TE. ...

Knot scale 1 have present in
board TE. ...

COUPE B' Ech. 1/2
SECTION B' Scale 1/2

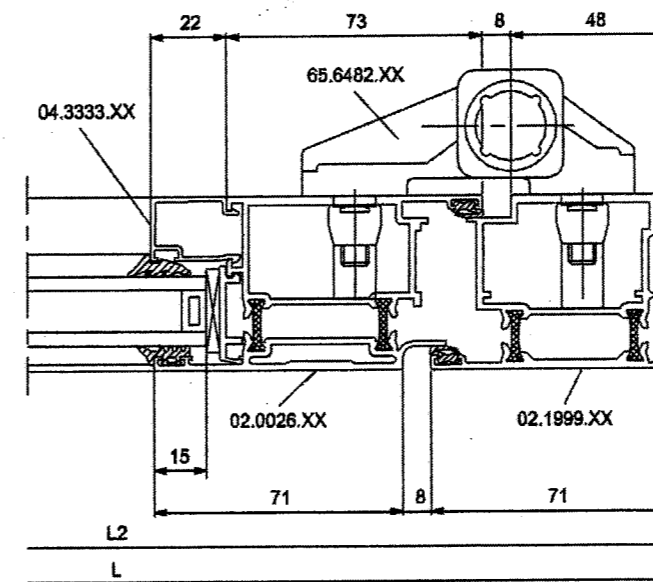
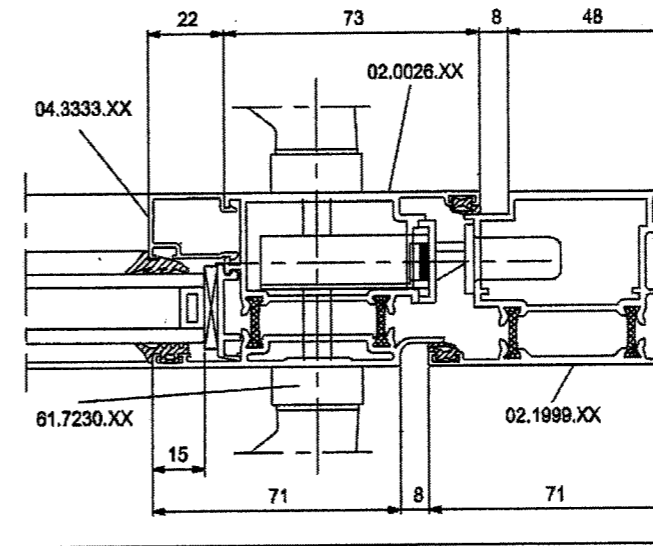
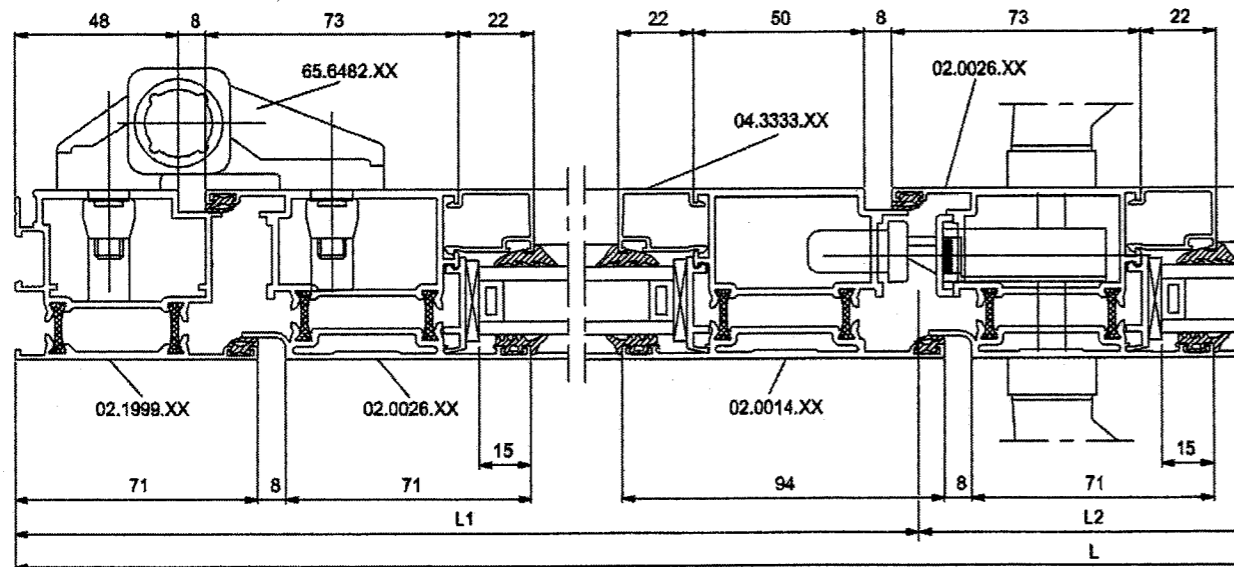



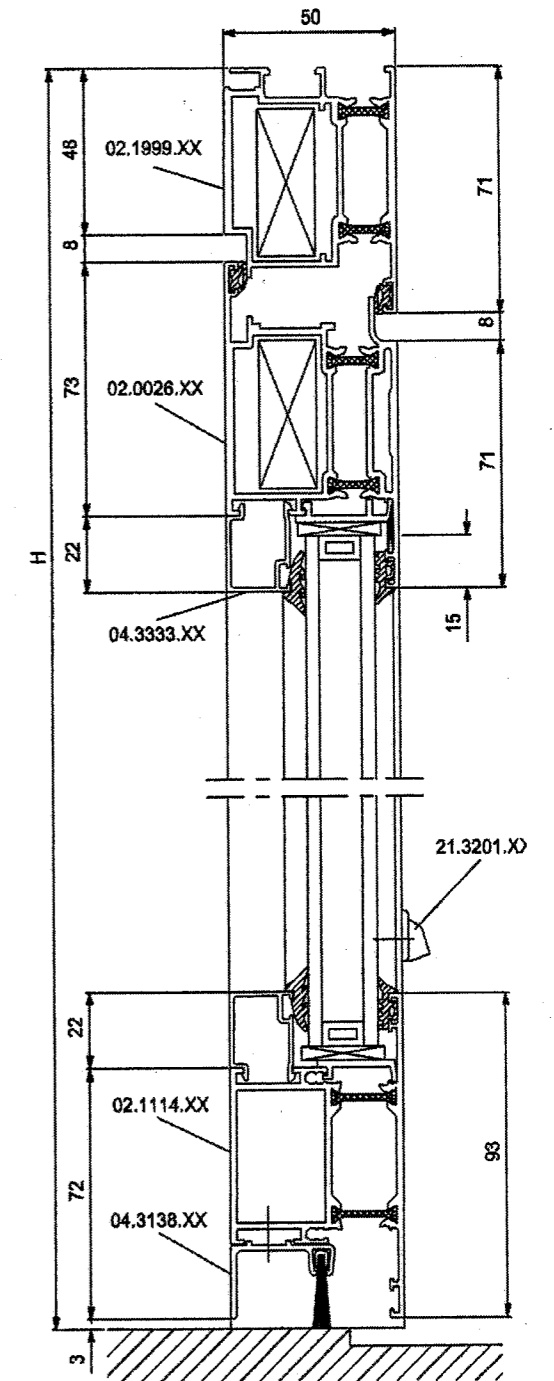





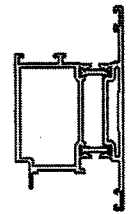

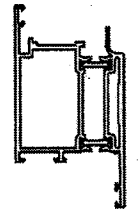



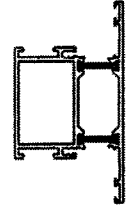

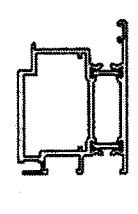
COUPE A Ech. 1/2
SECTION A Scale 1/2



**DOCUMENT GAMMISTE PORTE BATTANTE SANS SEUIL
OUVERTURE VERS L'INTERIEUR 1 ET 2 VANTAUX**
Nomenclature et débits

PROFILES / PROFILS

REFERENCE REFERENCE	DESIGNATION DESCRIPTION	PROFILE PROFILE	COUPE SECTION	1 VANTAIL / 1 VENT		2 VANTAUX / 2 VENTS	
				Q	D / S	Q	D / S
02.0014.XX	OUVRANT PORTE-T** VENT DOOR**			-	-	1	H - 59
02.0026.XX	OUVRANT PORTE Z** VENT Z**		  	1	H - 59	1	H - 59
				1	H - 59	2	H - 59
				1	L - 112	1	L1-48.5
						1	L2-48.5
02.1114.XX	TRAVERSE 93mm TRANSOM 93mm			1	L - 258	2	L1 -194,5 L2 -194,5
02.1999.XX	DORMANT PORTE OUTER FRAME DOOR		  	1	H	1	H
				1	H	1	H
				1	L	1	L
04.3138.XX	PROFILE SUPPORT BROSSE SUR T BOTTOM DOOR RAIL			1	L - 258 H	2	L1 -194,5 L2 -194,5
04.3333.XX	PARCLOSE DE 18,5mm GLAZING BEAD VENT 18,5mm			2	L - 258	2	L1 -194,5
				2	H - 248	2	L2 -194,5
						4	H - 248

IMPORTANT : Dans le cas d'une ouverture vers l'extérieur, le profilé 02.0014.XX est remplacé par le 02.0026.XX, les profilés 02.0026.XX par des 02.0014.XX et les 02.1999.XX par des 02.1969.XX

COUPES PROFILS DE LA PORTE :

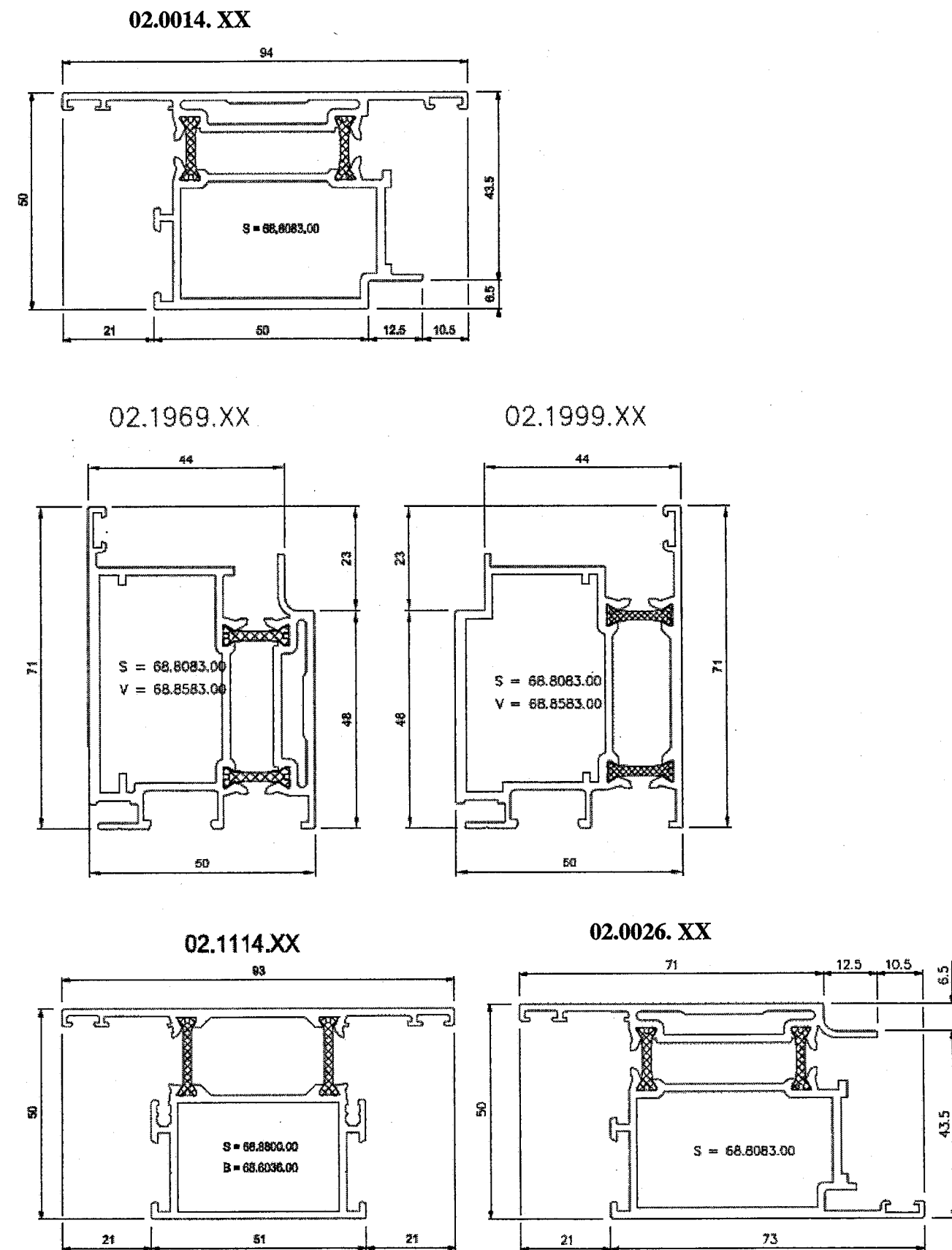

COUPES HORIZONTALE ET VERTICALE DU CHASSIS FIXE REP. D

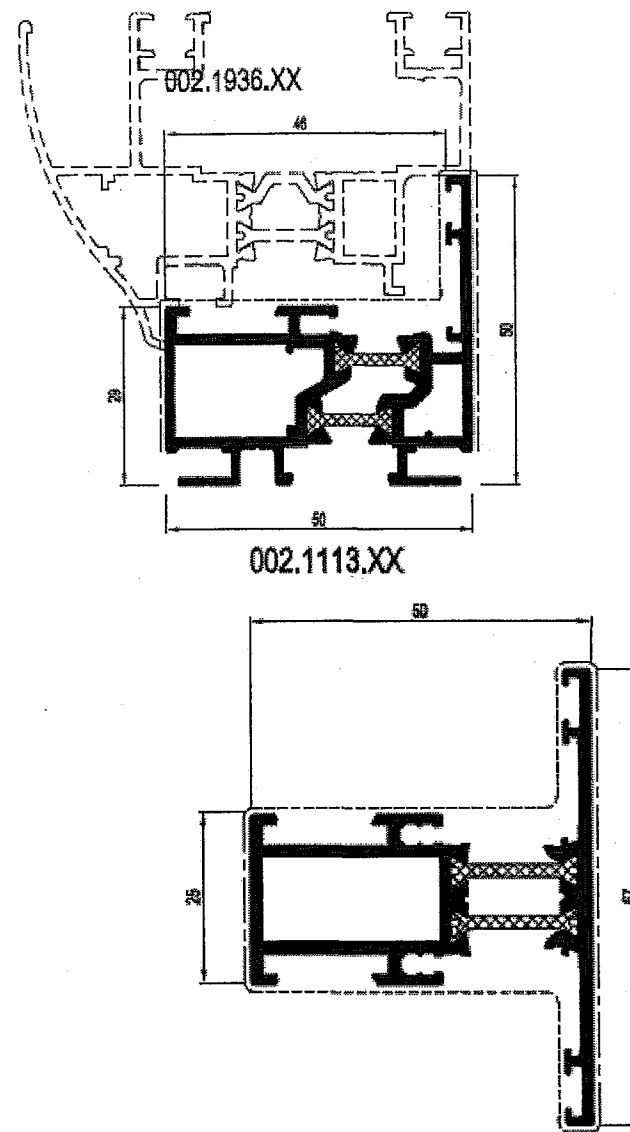
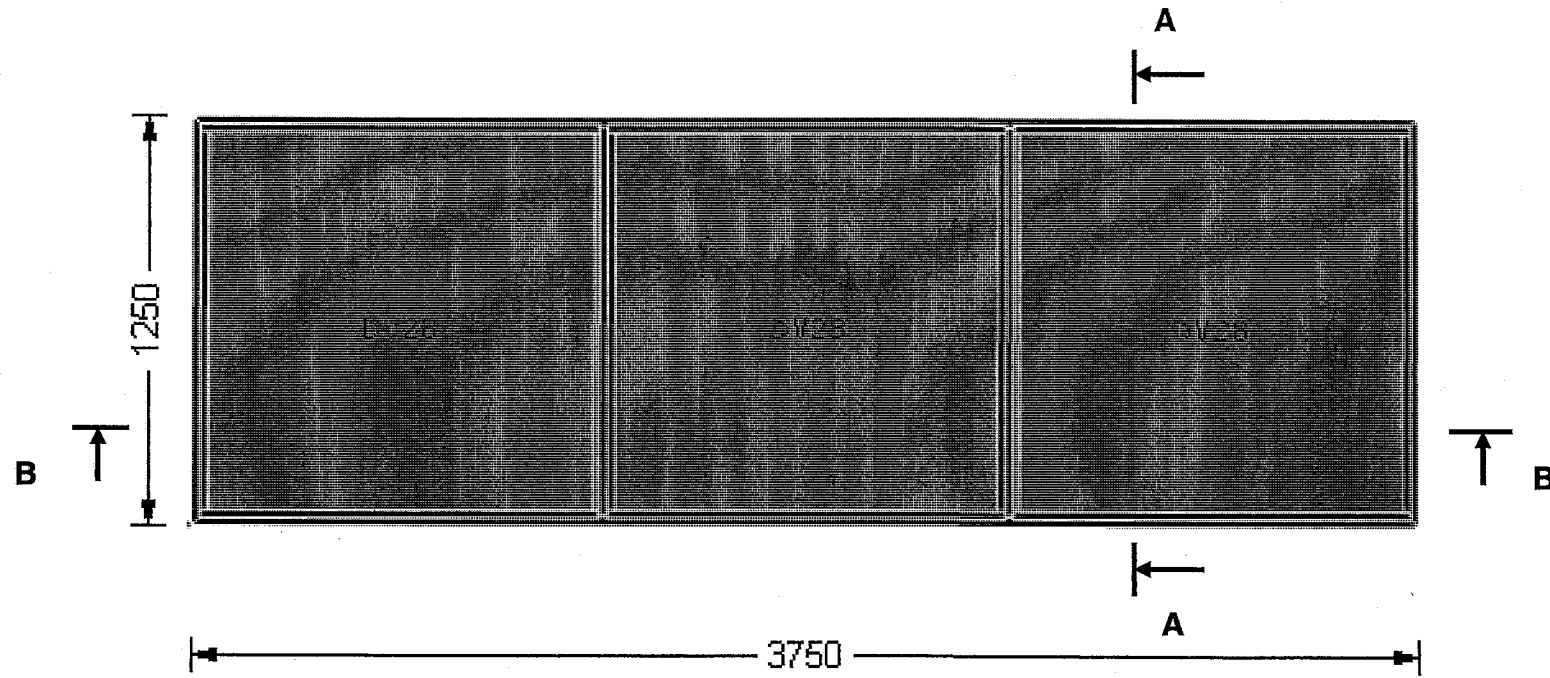

COUPE VERTICALE A-A

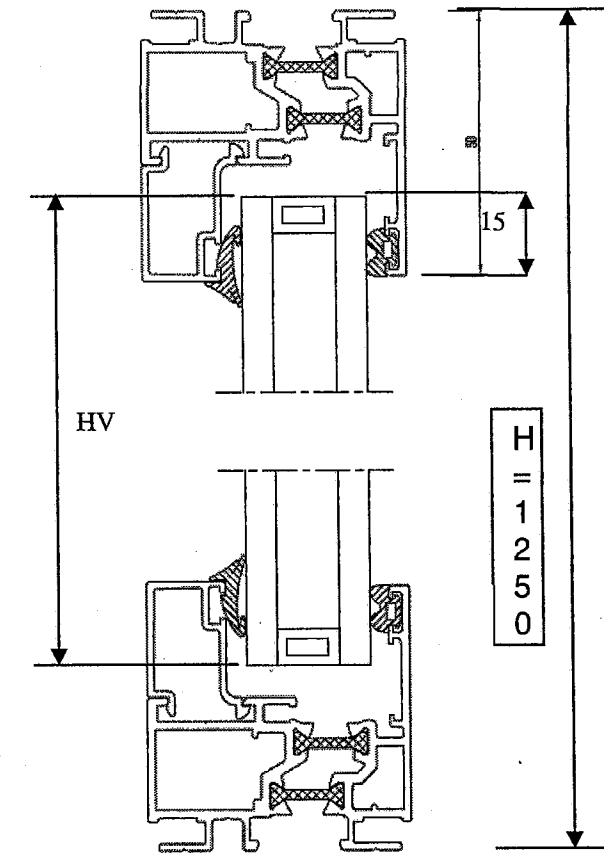

COUPE HORIZONTALE B-B



PLANCHE DE MONTAGE EQUERRES ET BLOCS D'ASSEMBLAGE :

ASSEMBLAGE PAR SERTISSAGE ASSEMBLY BY CRIMPING

066.7572.00 066.8180.00

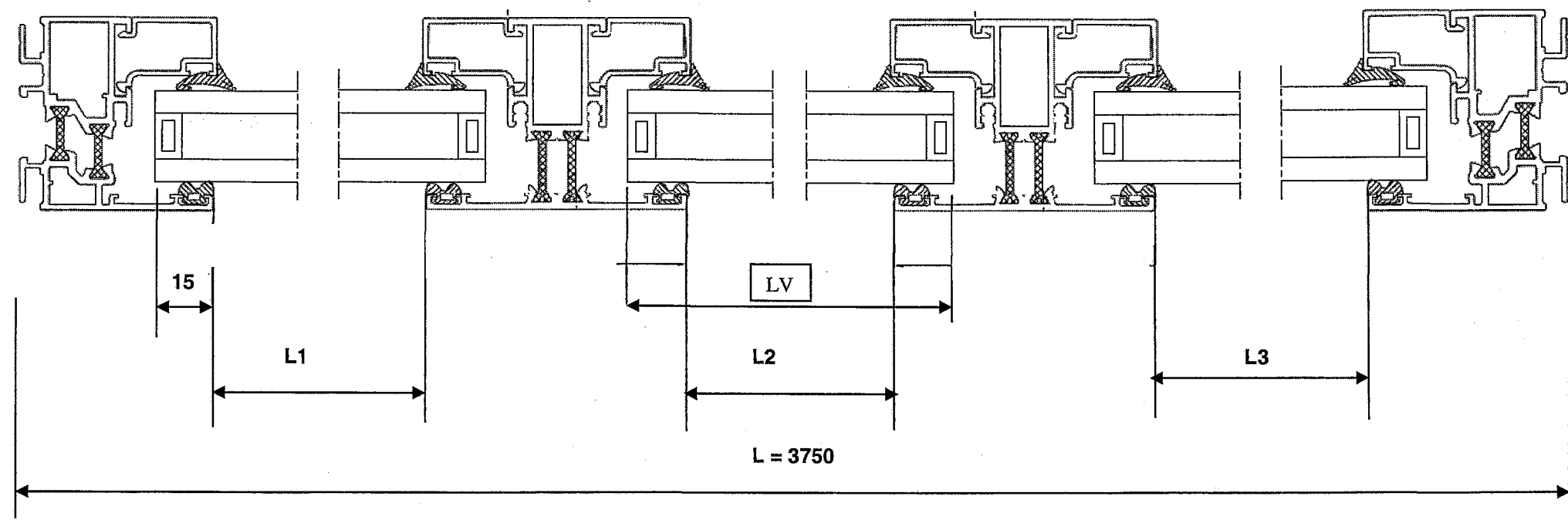
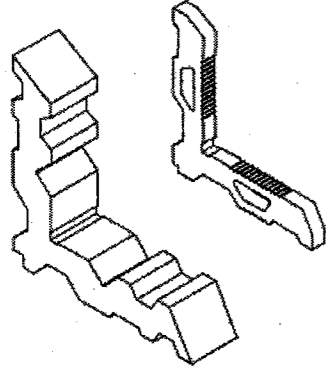

NOTA (CF norme NF P 24-301)

Pour l'assemblage

- ① Etancher le bloc par application de mastic élastomère 1ère catégorie dans les tubulures;
- ② Etancher la coupe au mastic fluide (En zone littoral appliquer du produit anti-corrosion référence 086.9608.- -)

NOTE (CF standard NF P 24-301)

For assembly

- ① Seal the block by means of sealing agent 1st cat. in outer frame
- ② Seal the saw cut by means of liquid sealing agent. (In littoral zone, applying a corrosion preventing agent ref : 086.9608.- -)

ASSEMBLAGE PAR VISSAGE ASSEMBLY BY SCREWING

066.8583.00 066.8180.00

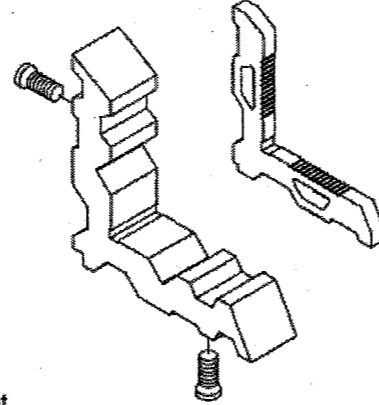

002.1936.XX
ou/ou 002.1950.XX

002.1936.XX
ou/ou 002.1950.XX

Clé 6 pans de 4
Socket head wrench 4

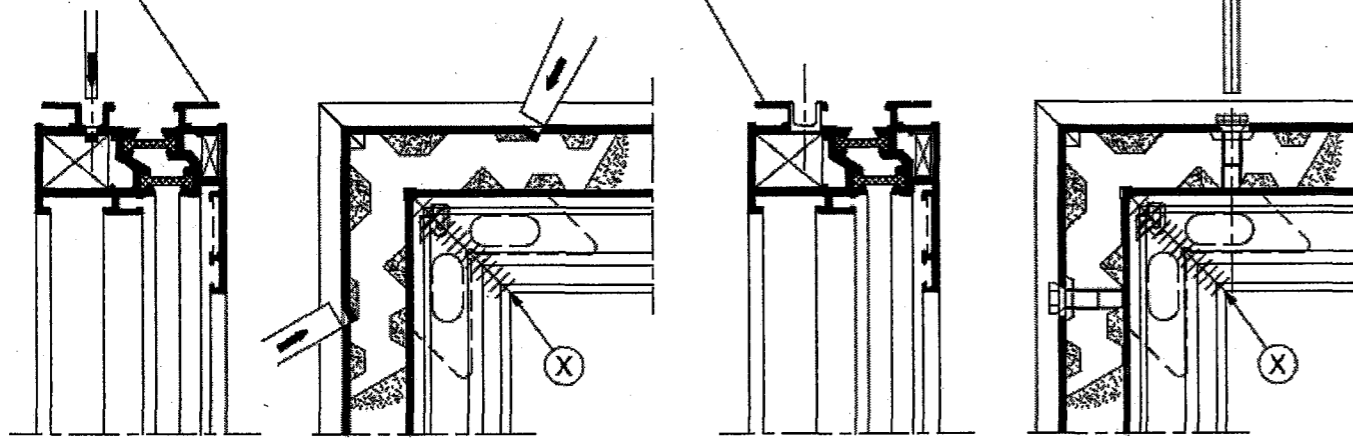

060.8720.- -

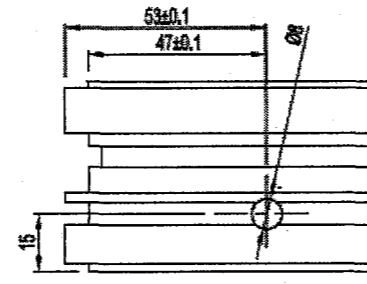
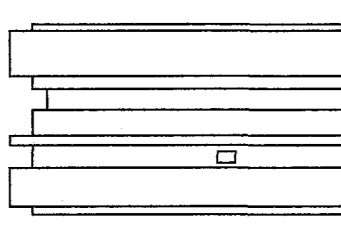
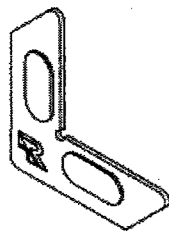

ASSEMBLAGE PAR JONCTION-T ASSEMBLY BY T-BRACKET

CORRESPONDANCE	
PROFILES	JONCTION - T/ T-BRACKET
002.1900.XX	066.6855.00
002.1910.XX	
002.1911.XX	
002.1113.XX	066.8750.00
002.1120.XX	066.8751.00
002.1114.XX	066.8752.00

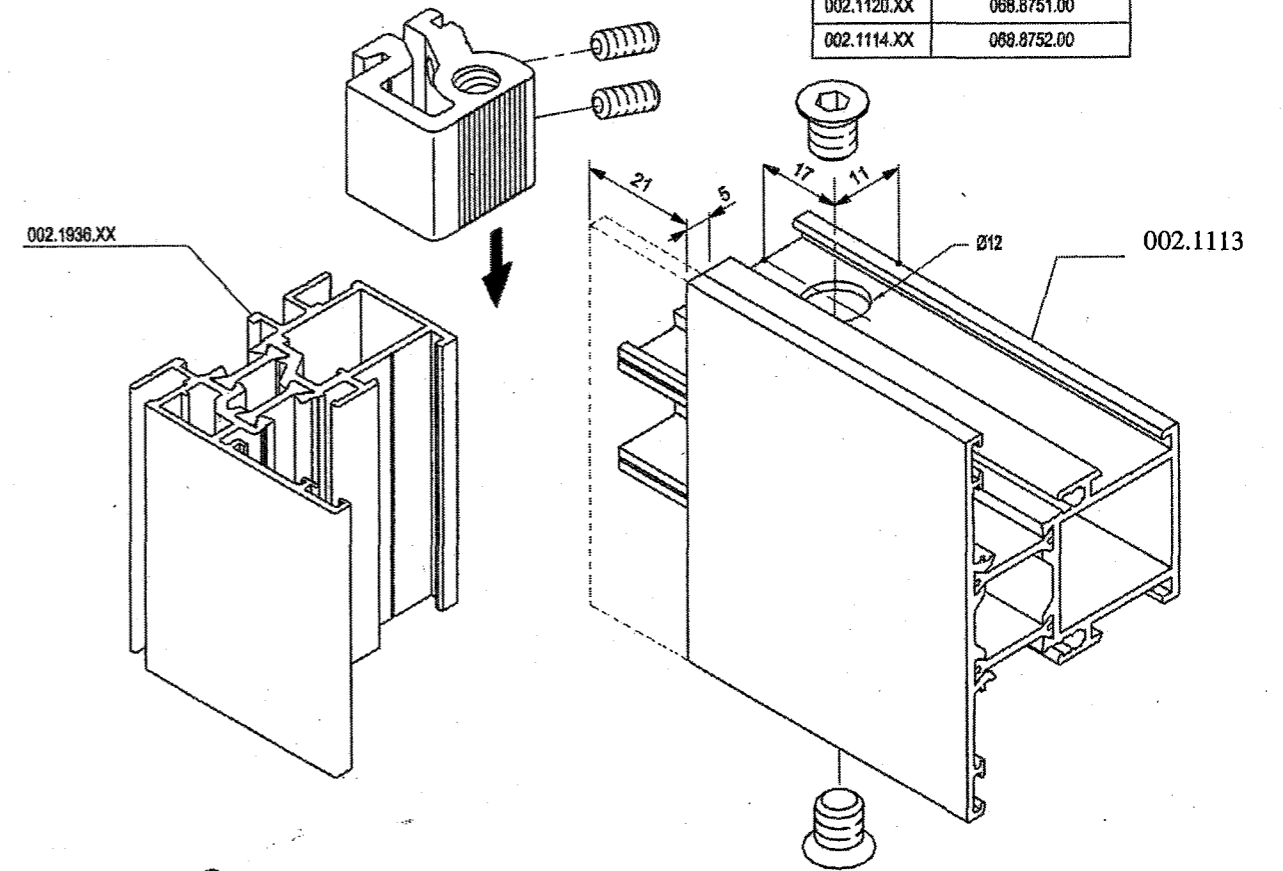

002.1936.XX

002.1113

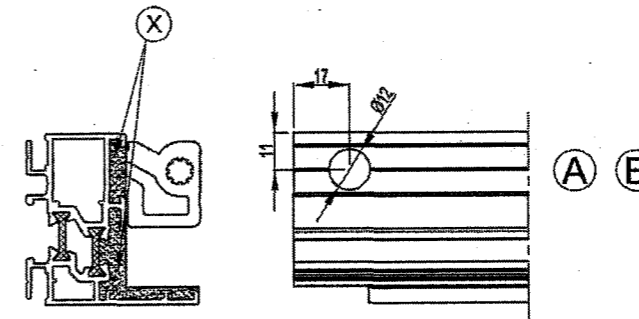

NOTA (CF norme NF P 24-301)

Pour l'assemblage

- ① Etancher le bloc par application de mastic élastomère 1ère catégorie dans les tubulures;
- ② Etancher la coupe au mastic fluide (En zone littoral appliquer du produit anti-corrosion référence 086.9608.- -)

NOTE (CF standard NF P 24-301)

For assembly

- ① Seal the block by means of sealing agent 1st cat. in outer frame
- ② Seal the saw cut by means of liquid sealing agent. (In littoral zone, applying a corrosion preventing agent ref : 086.9608.- -)

CALIBRE DE PERÇAGE
BORING JIG 097.0092.00 A

MATRICE GUIDÉE MULTIFONCTIONNELLE
MULTIFUNCTIONAL PUNCH TOOL 097.C500.00 B

X MATIÈRE D'ÉTANCHÉITE
SEALING AGENT

FICHE TECHNIQUE FRAISEUSE EN BOUT

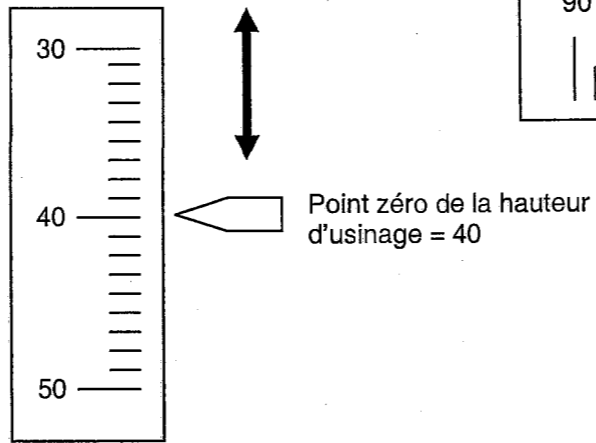
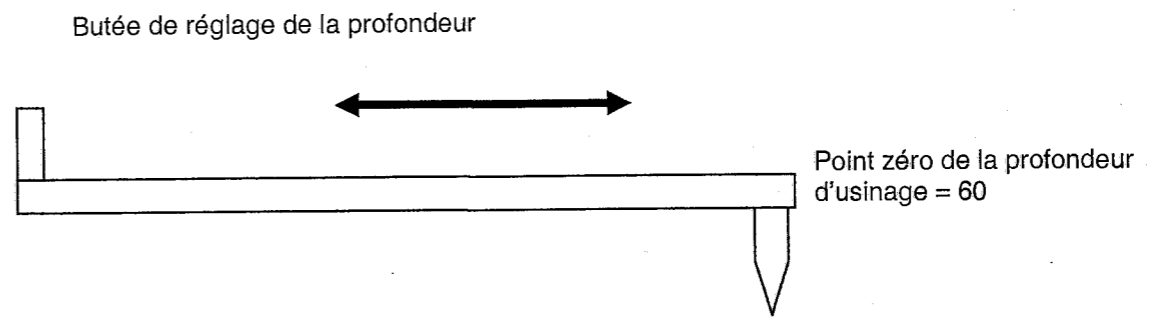
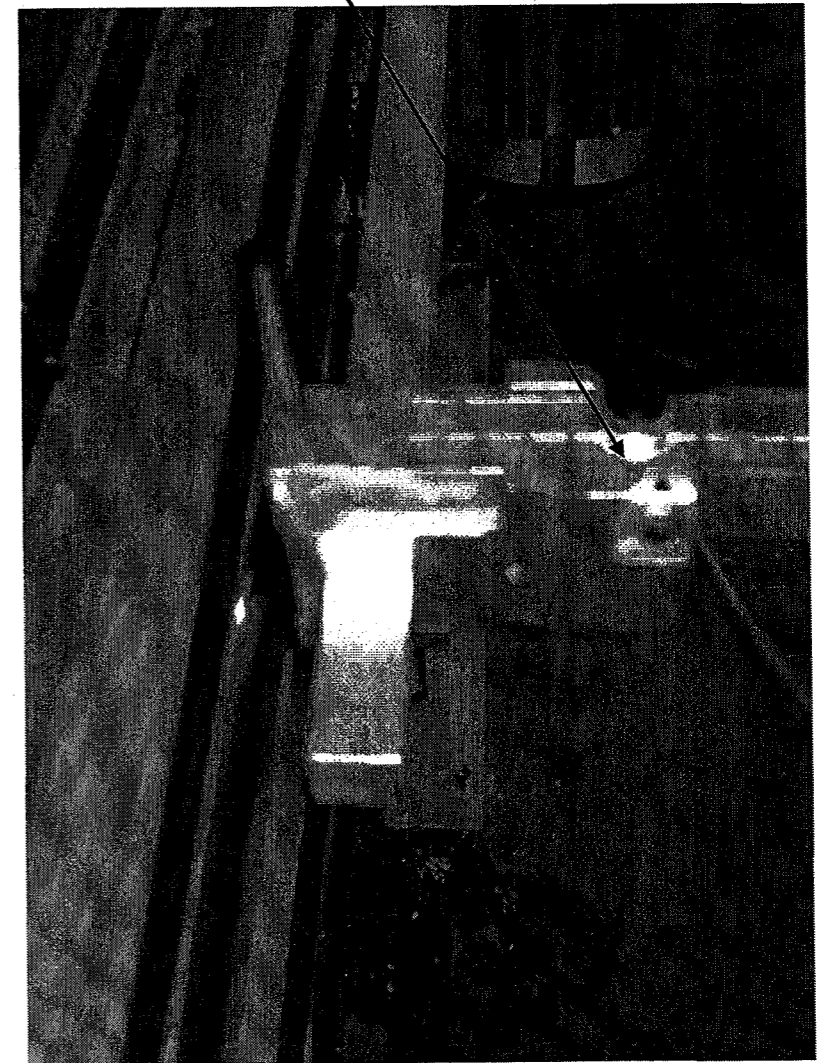
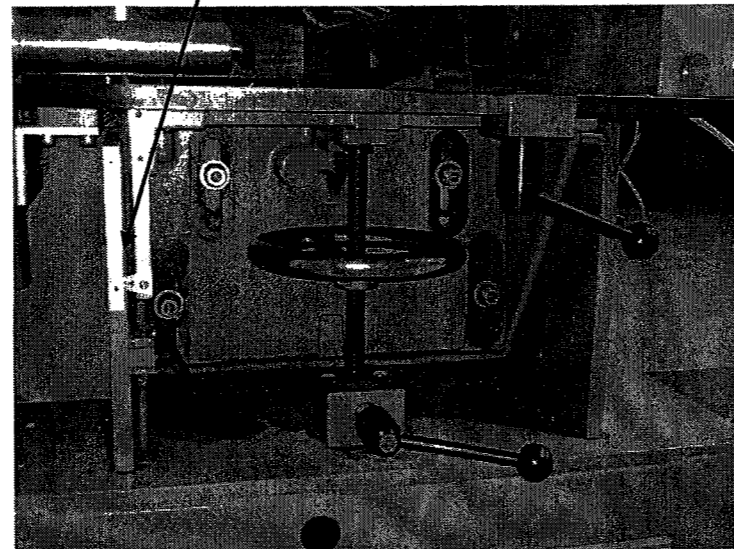
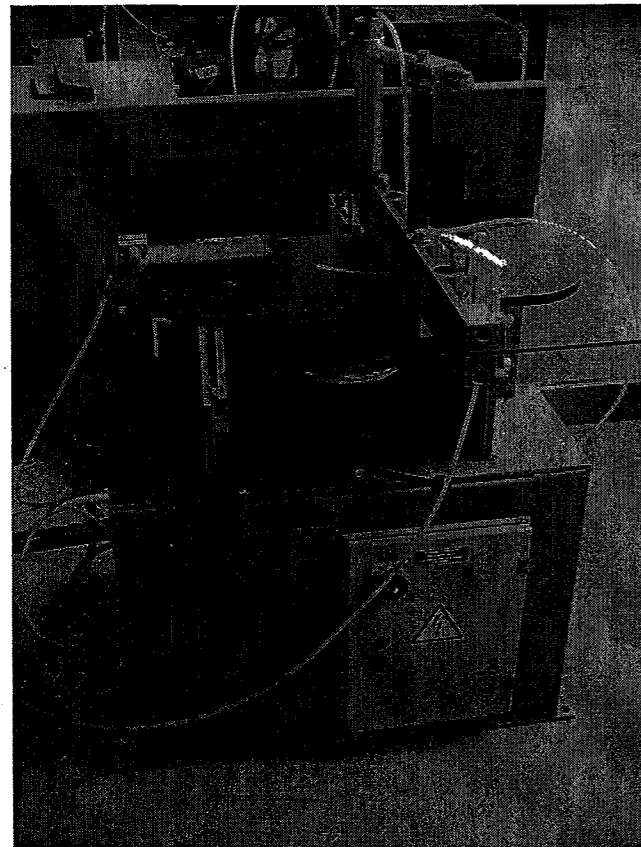

FICHE TECHNIQUE FRAISEUSE EN BOUT ET SYMBOLISATION ISOSTATISME

Élévation

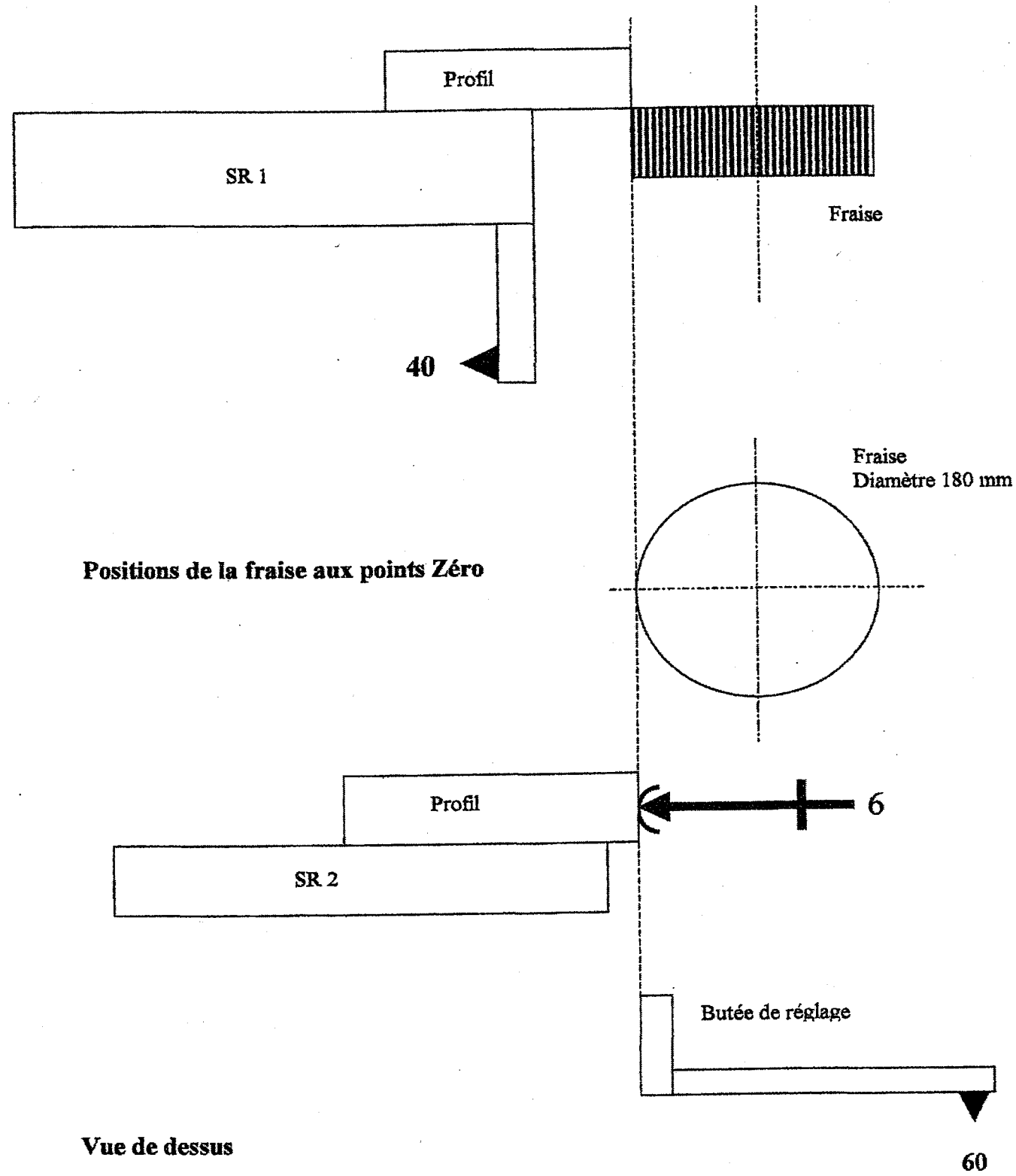

Vue de dessus

Symbolisation d'isostatisme

Symbolisation des éléments d'appui et de maintien

	Profil	Projection
Appui fixe		
Centrage fixe		
Système à serrage		

Symbolisation de la nature de la surface de contact de la pièce

Appui sur une surface brute :		
Appui sur une surface usinée :		

Symboles indiquant la nature du contact avec la surface la pièce

Contact ponctuel :		Symbole :
Contact surfacique :		Symbole :

FICHE DE DEBIT MUR-RIDEAU REPERE P

Profils

Qté		Position	L. scie	Angle 1	Angle 2	Référence
0340536.59 7016 <i>PROFILE DE RECOUVREMENT 15MM</i> RAL 60µ BRILL CAT 2 (Gris anthracite) 						
1x	*		1172,8mm	86,7°	93,3°	GIRODREP P*00001*1
11x	-		1168,0mm	90,0°	90,0°	GIRODREP P*00001*1
2x	*		1147,8mm	86,7°	93,3°	GIRODREP P*00001*1
22x	-		1143,0mm	90,0°	90,0°	GIRODREP P*00001*1

Qté		Position	L. scie	Angle 1	Angle 2	Référence
0340537.59 7016 <i>PROFILE DE RECOUVREMENT 18MM</i> RAL 60µ BRILL CAT 2 (Gris anthracite) 						
1x			5060,0mm	90,0°	86,7°	GIRODREP P*00001*1
1x			4991,4mm	90,0°	93,3°	GIRODREP P*00001*1
1x			4921,4mm	90,0°	93,3°	GIRODREP P*00001*1
1x			4852,9mm	90,0°	93,3°	GIRODREP P*00001*1

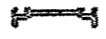
Qté		Position	L. scie	Angle 1	Angle 2	Référence
0340556.00 <i>SERREUR VERTICAL</i> BRUT 						
1x			5060,0mm	90,0°	86,7°	GIRODREP P*00001*1
1x			4991,4mm	90,0°	93,3°	GIRODREP P*00001*1
1x			4921,4mm	90,0°	93,3°	GIRODREP P*00001*1
1x			4852,7mm	90,0°	93,3°	GIRODREP P*00001*1

Qté		Position	L. scie	Angle 1	Angle 2	Référence
0341507.59 7016 <i>MENEAU 184MM</i> RAL 60µ BRILL CAT 2 (Gris anthracite) 						
1x			5060,0mm	86,7°	90,0°	GIRODREP P*00001*1
1x			4991,4mm	90,0°	93,3°	GIRODREP P*00001*1
1x			4921,4mm	90,0°	93,3°	GIRODREP P*00001*1
1x			4852,9mm	90,0°	93,3°	GIRODREP P*00001*1

Qté		Position	L. scie	Angle 1	Angle 2	Référence
0342522.59 7016 <i>TRAVERSE 67.2MM</i> RAL 60µ BRILL CAT 2 (Gris anthracite) 						
1x	*		1204,8mm	93,3°	86,7°	GIRODREP P*00001*1
11x	-		1200,0mm	90,0°	90,0°	GIRODREP P*00001*1
2x	*		1179,8mm	93,3°	86,7°	GIRODREP P*00001*1
22x	-		1175,0mm	90,0°	90,0°	GIRODREP P*00001*1

Qté		Position	L. scie	Angle 1	Angle 2	Référence
0342535.00 <i>SERREUR H</i> BRUT 						
1x	*		1170,8mm	86,7°	93,3°	GIRODREP P*00001*1
11x	-		1166,0mm	90,0°	90,0°	GIRODREP P*00001*1
2x	*		1145,8mm	86,7°	93,3°	GIRODREP P*00001*1
22x	-		1141,0mm	90,0°	90,0°	GIRODREP P*00001*1

EXEMPLE DE MISE EN BARRE :

DORMANT 021936

Pièces à réaliser (débit):

- 3 pièces de 2900 mm
- 2 pièces de 2700 mm
- 8 pièces de 2445 mm
- 2 pièces de 1050 mm
- 4 pièces de 941 mm
- 2 pièces de 907 mm

Longueur des barres : 6500 mm
Contraintes de débit sur tronçonneuse deux têtes :

- Affranchissement de la barre : 30 mm
- Perte entre coupes : 10 mm
- Perte par coupe : 10 mm

	DEBIT	RESTE
BARRE 1	1*2900 + 1*2445 + 1*1050	5 mm
BARRE 2	1*2900 + 1*2445 + 1*1050	5 mm
BARRE 3	1*2900 + 1*2445 + 1*941	114 mm
BARRE 4	2*2700 + 1*941	59 mm
BARRE 5	1*2445 + 2*941 + 2*907	199 mm
BARRE 6	2*2445	1540 mm
BARRE 7	2*2445	1540 mm
BARRE 8		

BON DE COMMANDE

REFERENCE	DESIGNATION	NOMBRE DE BARRES
021936	DORMANT	7 barres